

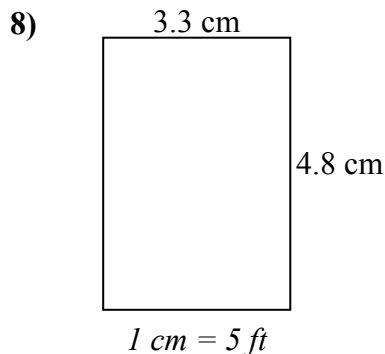

Xác định chiều rộng, chiều cao và diện tích thực của mỗi hình chữ nhật tỷ lệ. Làm tròn diện tích đến số nguyên gần nhất.

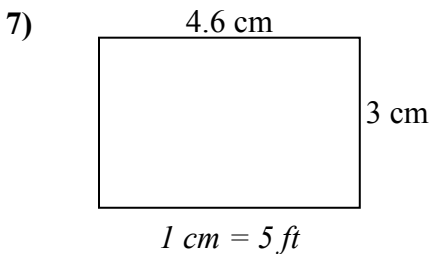
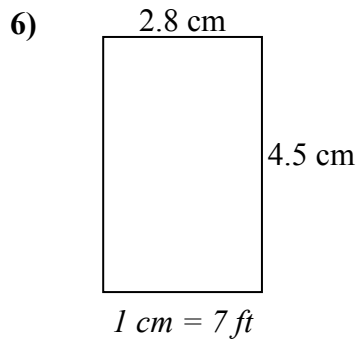
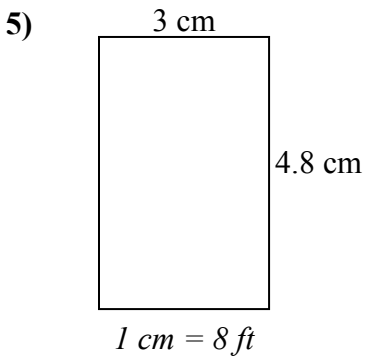
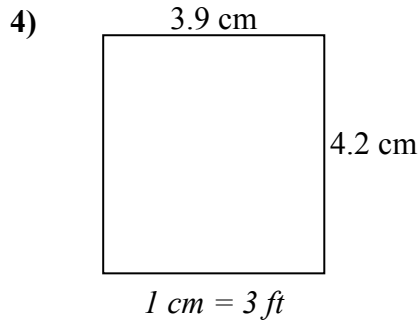
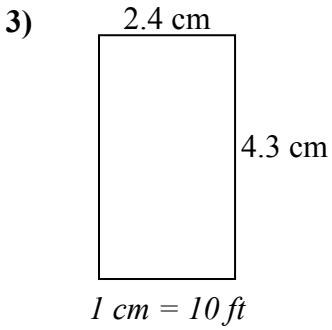
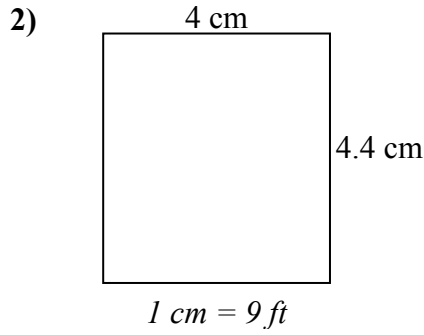
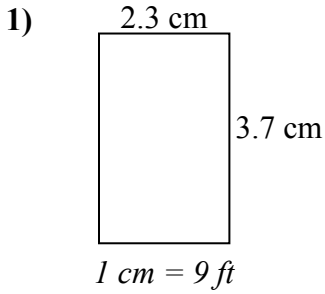

Câu trả lời

1. _____
2. _____
3. _____
4. _____
5. _____
6. _____
7. _____
8. _____



Xác định chiều rộng, chiều cao và diện tích thực của mỗi hình chữ nhật tỷ lệ. Làm tròn diện tích đến số nguyên gần nhất.

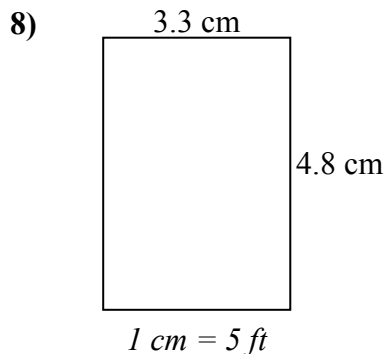
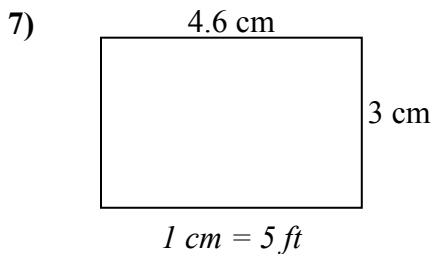
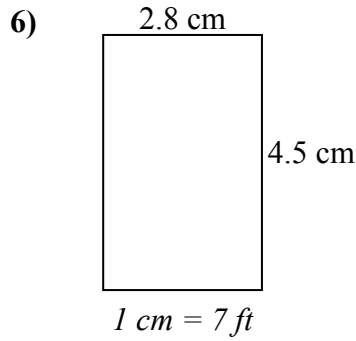
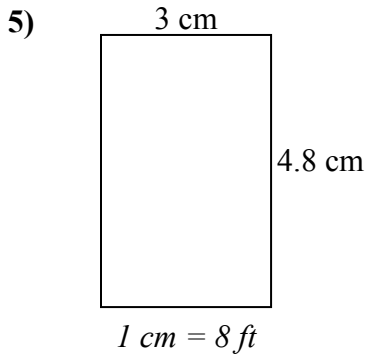
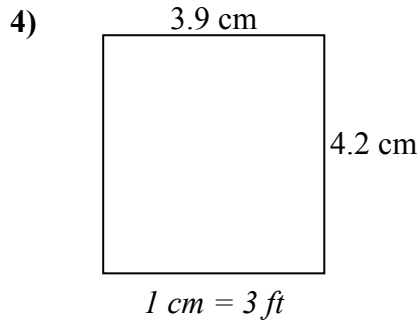
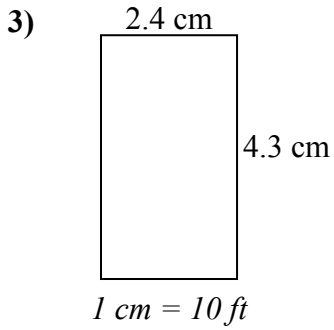
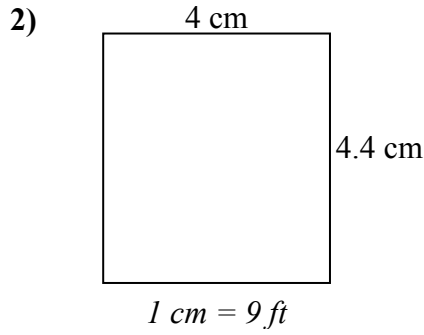
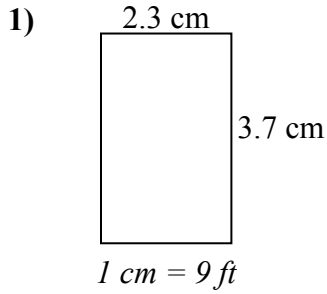

Câu trả lời

1. 20.7 33.3 689
2. 36 39.6 1.426
3. 24 43 1.032
4. 11.7 12.6 147
5. 24 38.4 922
6. 19.6 31.5 617
7. 23 15 345
8. 16.5 24 396



Xác định chiều rộng, chiều cao và diện tích thực của mỗi hình chữ nhật tỷ lệ. Làm tròn diện tích đến số nguyên gần nhất.

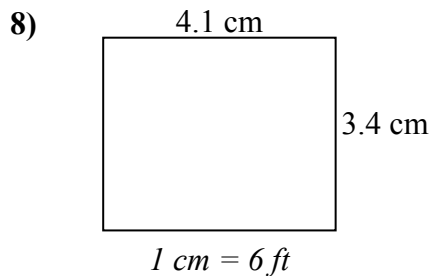
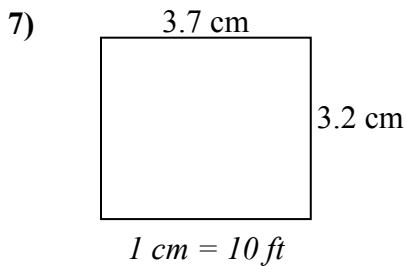
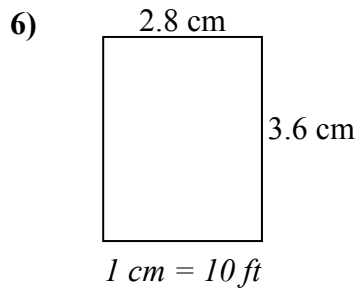
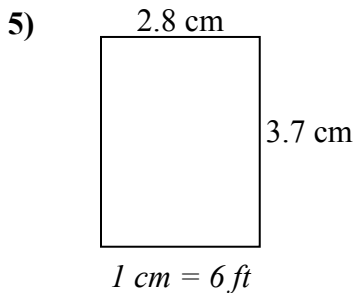
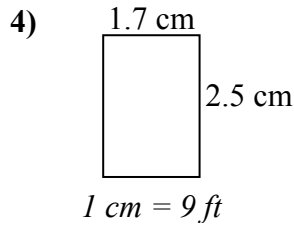
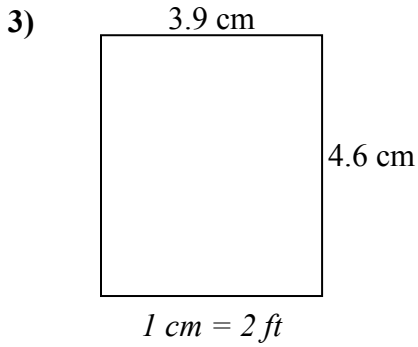
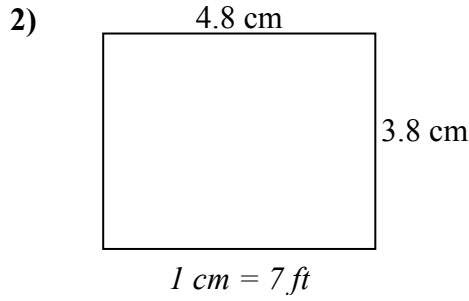
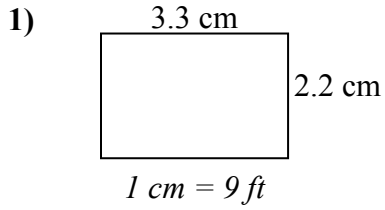

Câu trả lời

1. _____
2. _____
3. _____
4. _____
5. _____
6. _____
7. _____
8. _____



Xác định chiều rộng, chiều cao và diện tích thực của mỗi hình chữ nhật tỷ lệ. Làm tròn diện tích đến số nguyên gần nhất.

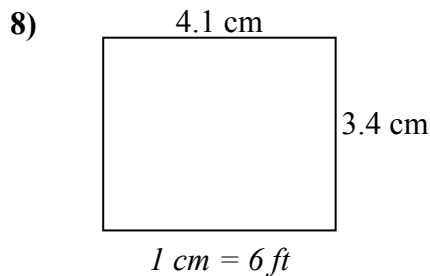
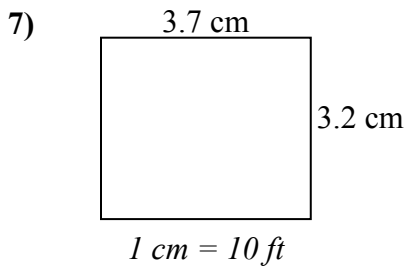
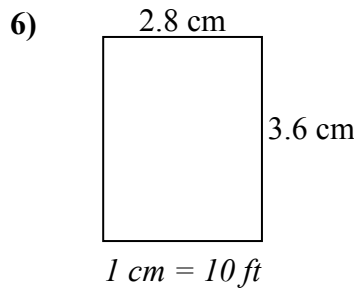
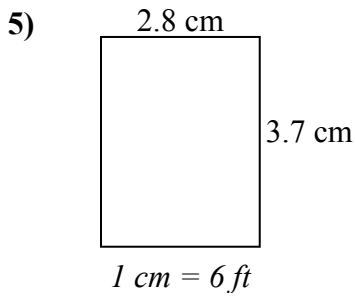
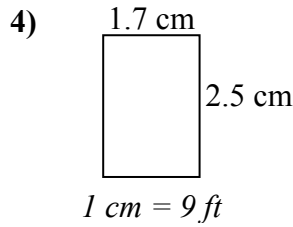
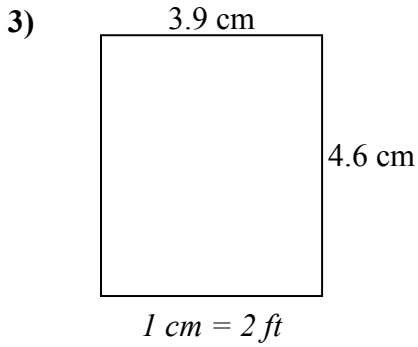
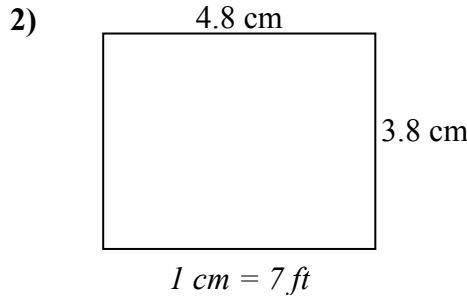
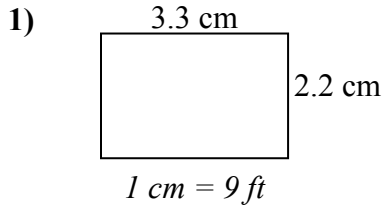

Câu trả lời

1. 29.7 19.8 588
2. 33.6 26.6 894
3. 7.8 9.2 72
4. 15.3 22.5 344
5. 16.8 22.2 373
6. 28 36 1.008
7. 37 32 1.184
8. 24.6 20.4 502



Xác định chiều rộng, chiều cao và diện tích thực của mỗi hình chữ nhật tỷ lệ. Làm tròn diện tích đến số nguyên gần nhất.

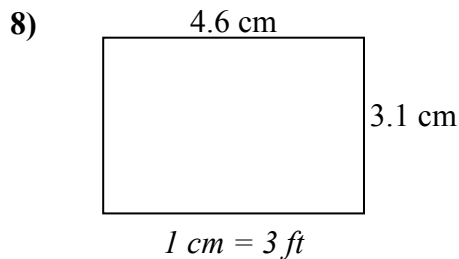
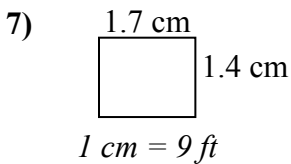
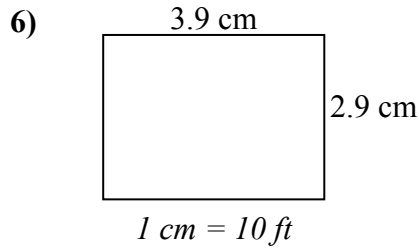
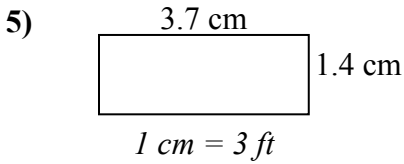
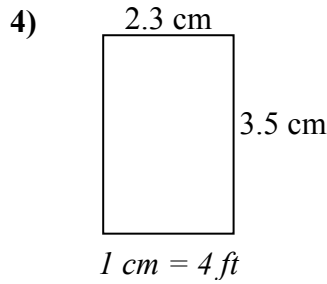
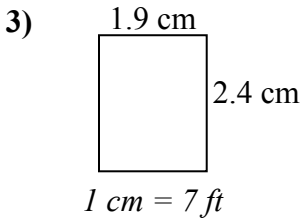
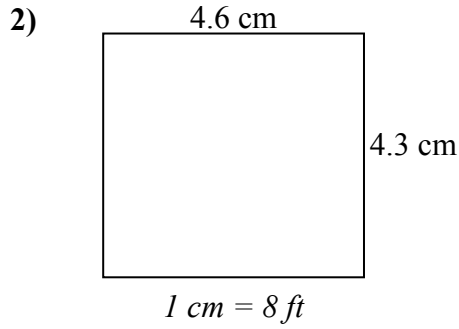
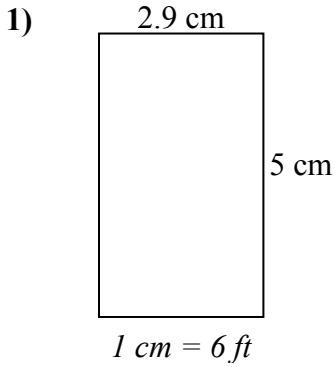

Câu trả lời

1. _____
2. _____
3. _____
4. _____
5. _____
6. _____
7. _____
8. _____



Xác định chiều rộng, chiều cao và diện tích thực của mỗi hình chữ nhật tỷ lệ. Làm tròn diện tích đến số nguyên gần nhất.

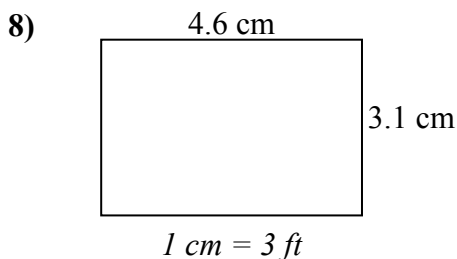
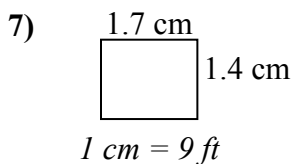
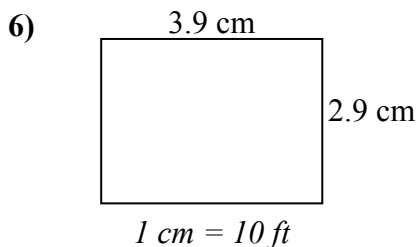
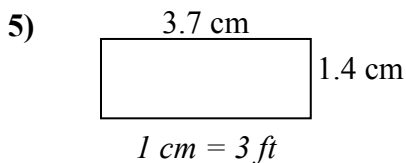
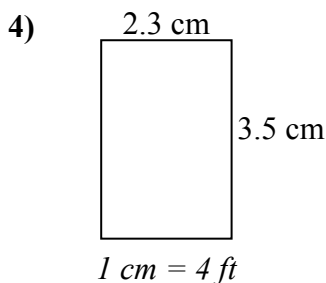
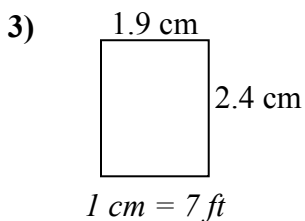
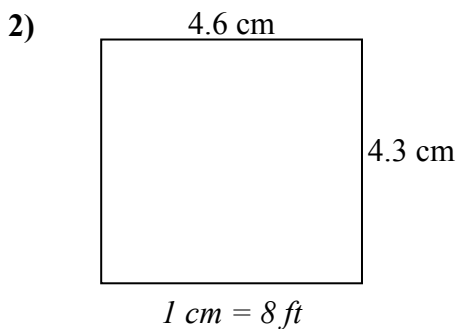
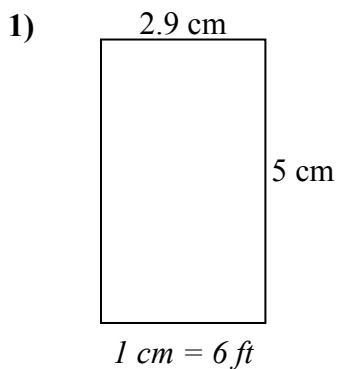

Câu trả lời

1. 17.4 30 522
2. 36.8 34.4 1.266
3. 13.3 16.8 223
4. 9.2 14 129
5. 11.1 4.2 47
6. 39 29 1.131
7. 15.3 12.6 193
8. 13.8 9.3 128



Xác định chiều rộng, chiều cao và diện tích thực của mỗi hình chữ nhật tỷ lệ. Làm tròn diện tích đến số nguyên gần nhất.

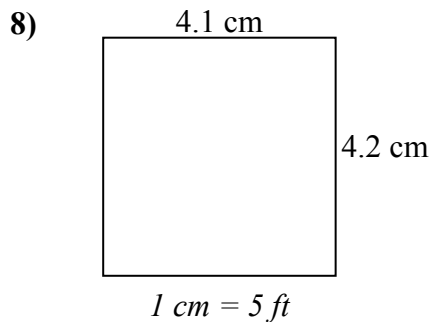
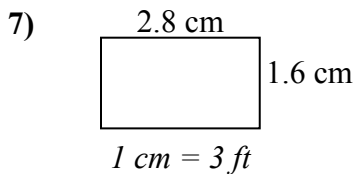
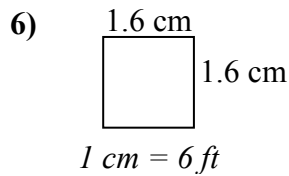
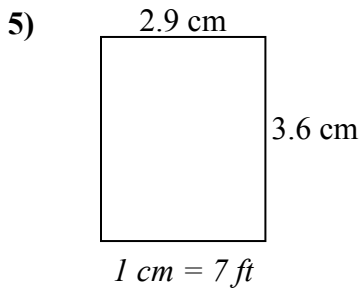
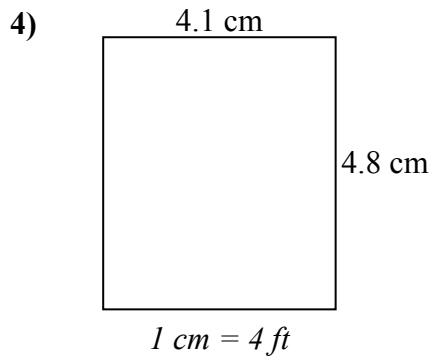
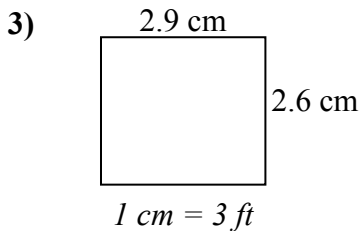
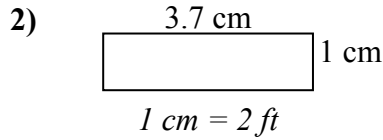
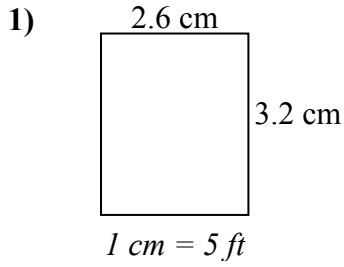

Câu trả lời

1. _____
2. _____
3. _____
4. _____
5. _____
6. _____
7. _____
8. _____



Xác định chiều rộng, chiều cao và diện tích thực của mỗi hình chữ nhật tỷ lệ. Làm tròn diện tích đến số nguyên gần nhất.

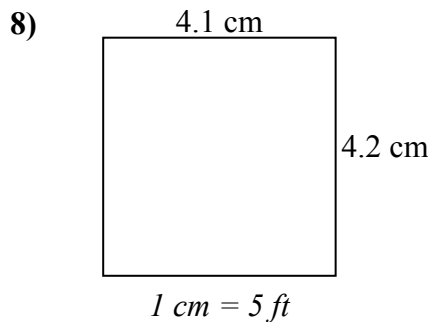
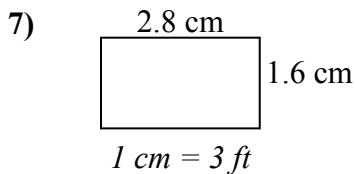
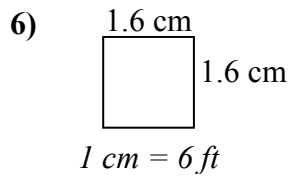
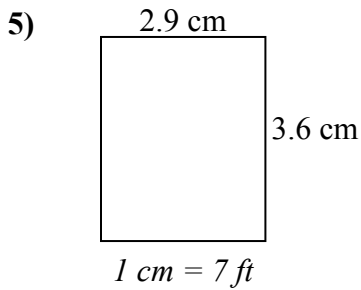
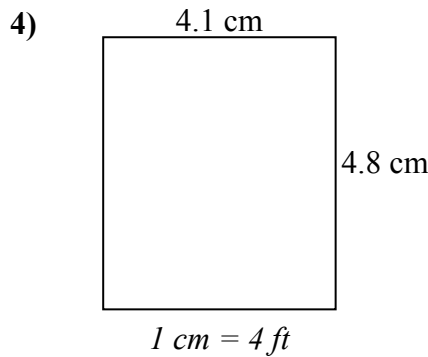
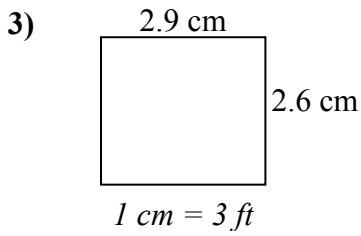
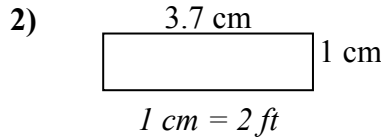
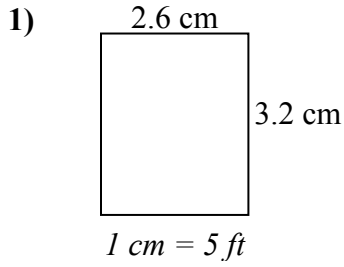

Câu trả lời

1.	<u>13</u>	<u>16</u>	<u>208</u>
2.	<u>7.4</u>	<u>2</u>	<u>15</u>
3.	<u>8.7</u>	<u>7.8</u>	<u>68</u>
4.	<u>16.4</u>	<u>19.2</u>	<u>315</u>
5.	<u>20.3</u>	<u>25.2</u>	<u>512</u>
6.	<u>9.6</u>	<u>9.6</u>	<u>92</u>
7.	<u>8.4</u>	<u>4.8</u>	<u>40</u>
8.	<u>20.5</u>	<u>21</u>	<u>431</u>



Xác định chiều rộng, chiều cao và diện tích thực của mỗi hình chữ nhật tỷ lệ. Làm tròn diện tích đến số nguyên gần nhất.

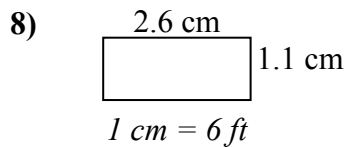
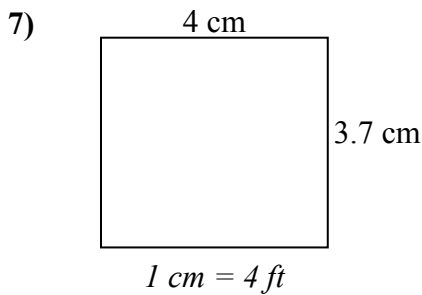
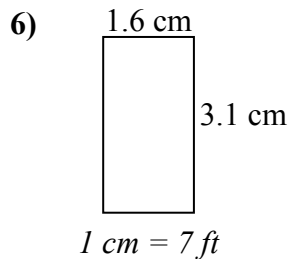
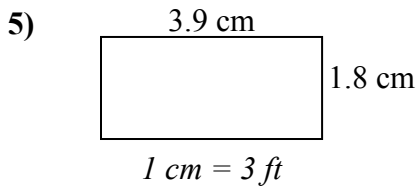
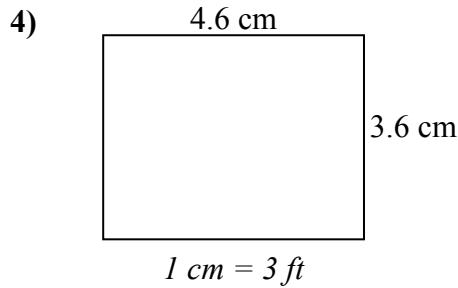
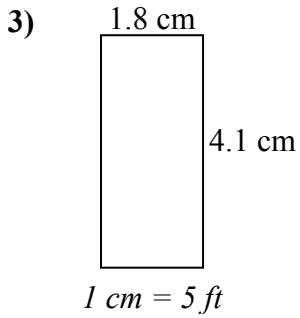
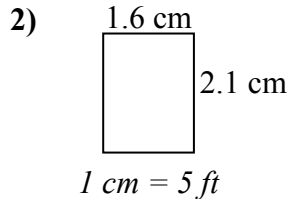
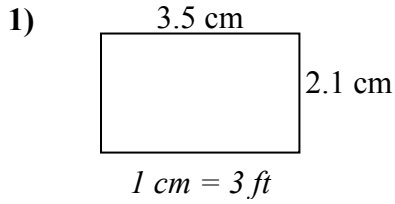

Câu trả lời

1. _____
2. _____
3. _____
4. _____
5. _____
6. _____
7. _____
8. _____



Xác định chiều rộng, chiều cao và diện tích thực của mỗi hình chữ nhật tỷ lệ. Làm tròn diện tích đến số nguyên gần nhất.

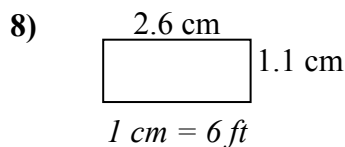
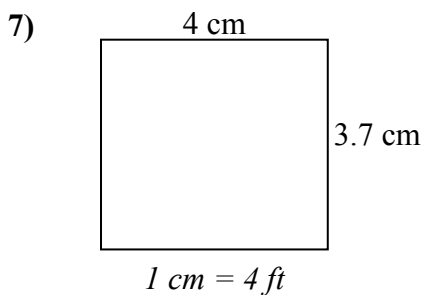
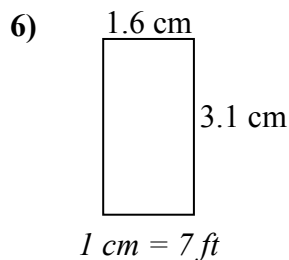
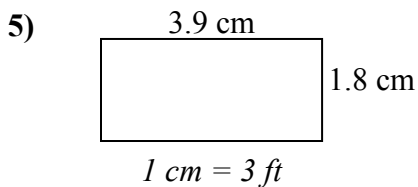
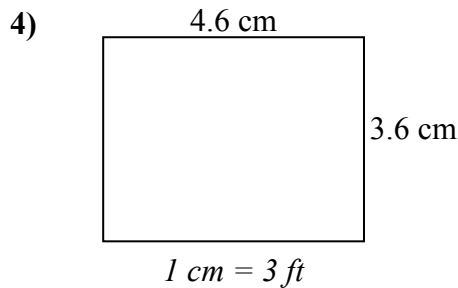
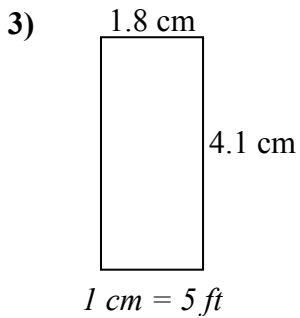
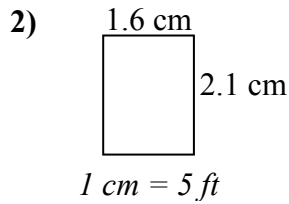
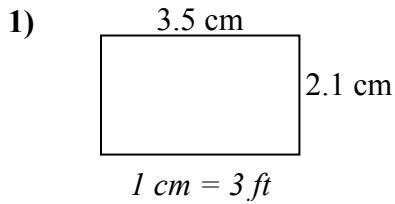

Câu trả lời

1. 10.5 6.3 66
2. 8 10.5 84
3. 9 20.5 185
4. 13.8 10.8 149
5. 11.7 5.4 63
6. 11.2 21.7 243
7. 16 14.8 237
8. 15.6 6.6 103



Xác định chiều rộng, chiều cao và diện tích thực của mỗi hình chữ nhật tỷ lệ. Làm tròn diện tích đến số nguyên gần nhất.

Câu trả lời

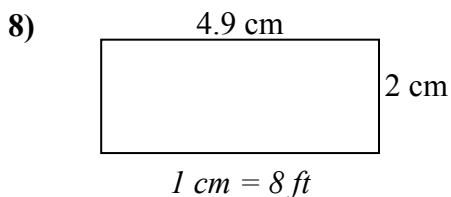
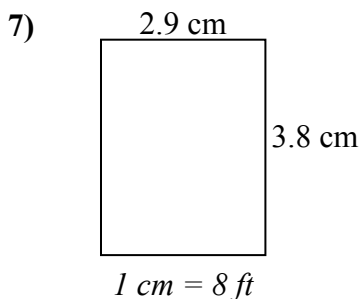
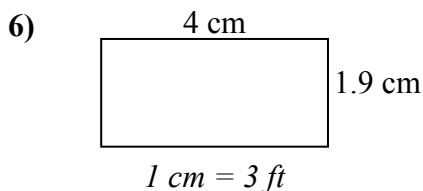
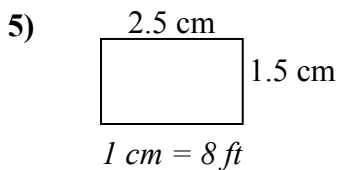
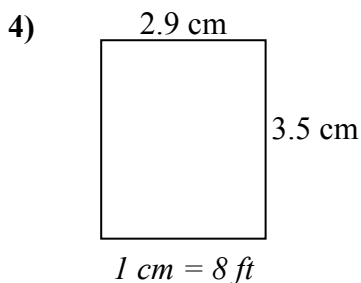
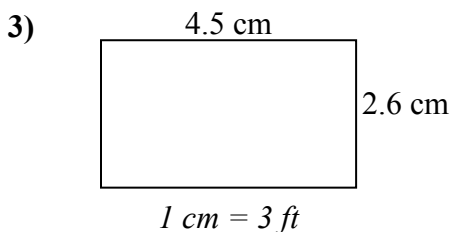
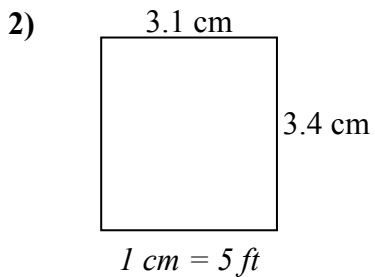
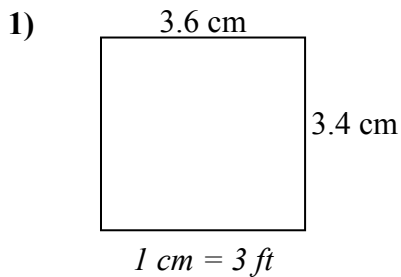

1. _____
2. _____
3. _____
4. _____
5. _____
6. _____
7. _____
8. _____



Xác định chiều rộng, chiều cao và diện tích thực của mỗi hình chữ nhật tỷ lệ. Làm tròn diện tích đến số nguyên gần nhất.

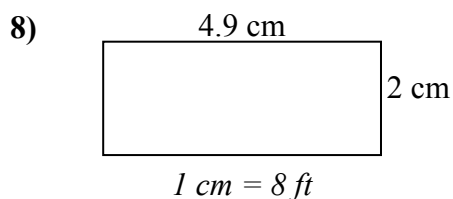
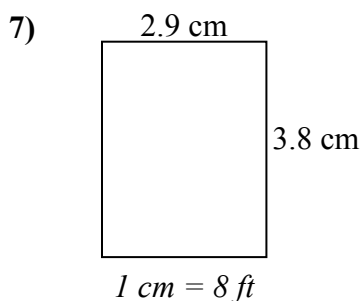
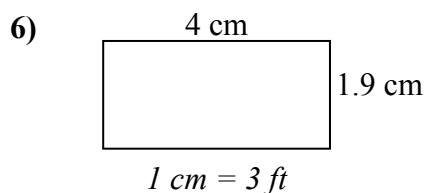
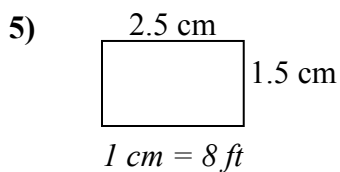
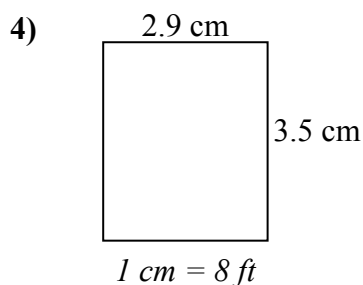
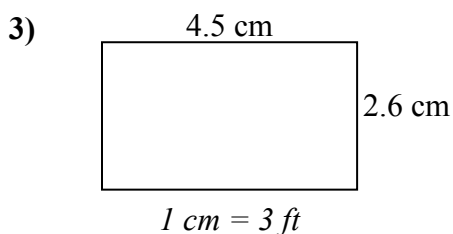
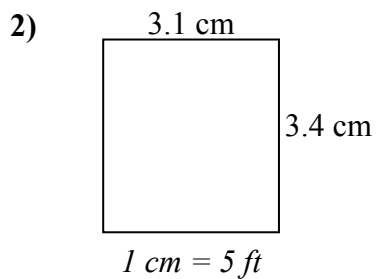
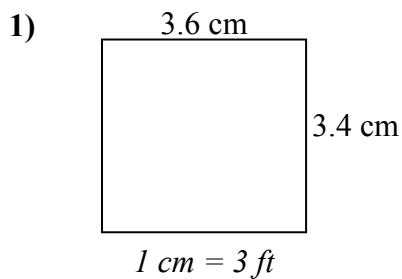

Câu trả lời

1. 10.8 10.2 110
2. 15.5 17 264
3. 13.5 7.8 105
4. 23.2 28 650
5. 20 12 240
6. 12 5.7 68
7. 23.2 30.4 705
8. 39.2 16 627



Xác định chiều rộng, chiều cao và diện tích thực của mỗi hình chữ nhật tỷ lệ. Làm tròn diện tích đến số nguyên gần nhất.

Câu trả lời

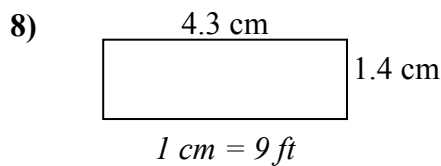
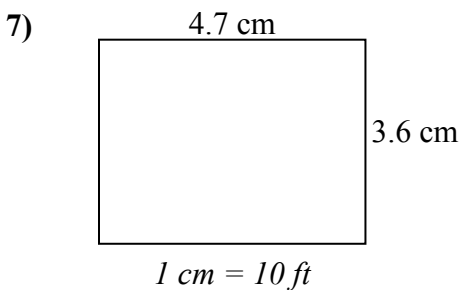
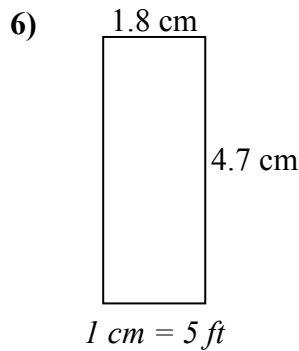
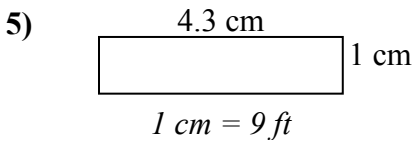
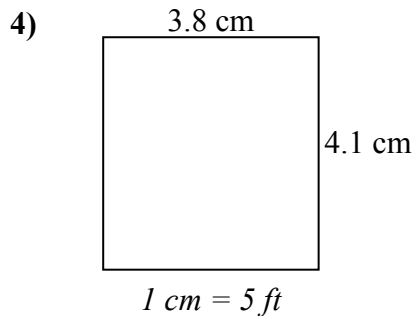
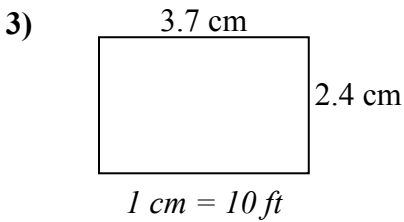
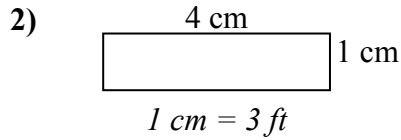
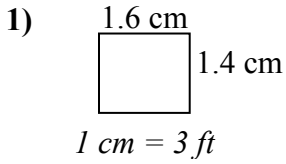

1. _____
2. _____
3. _____
4. _____
5. _____
6. _____
7. _____
8. _____



Xác định chiều rộng, chiều cao và diện tích thực của mỗi hình chữ nhật tỷ lệ. Làm tròn diện tích đến số nguyên gần nhất.

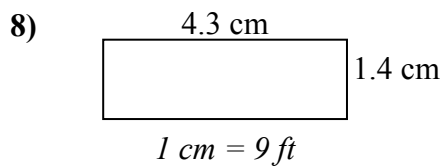
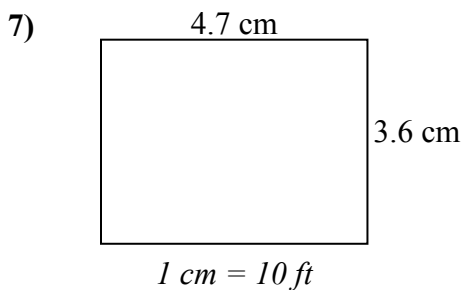
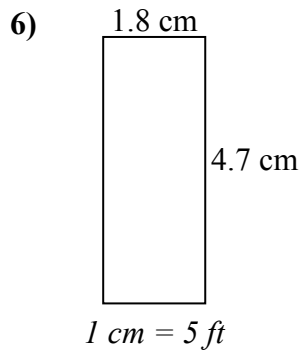
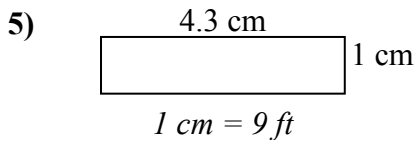
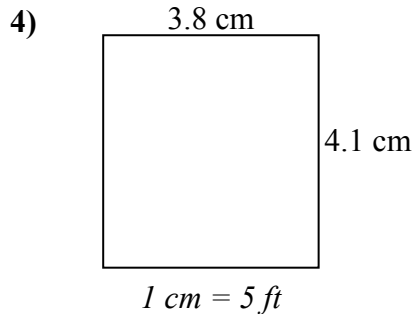
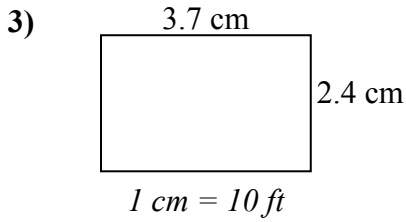
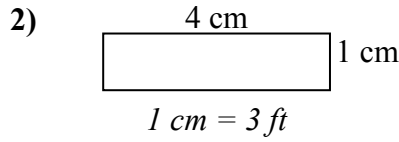
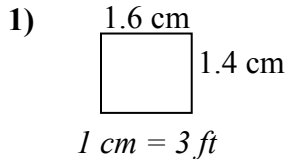

Câu trả lời

1.	<u>4.8</u>	<u>4.2</u>	<u>20</u>
2.	<u>12</u>	<u>3</u>	<u>36</u>
3.	<u>37</u>	<u>24</u>	<u>888</u>
4.	<u>19</u>	<u>20.5</u>	<u>390</u>
5.	<u>38.7</u>	<u>9</u>	<u>348</u>
6.	<u>9</u>	<u>23.5</u>	<u>212</u>
7.	<u>47</u>	<u>36</u>	<u>1.692</u>
8.	<u>38.7</u>	<u>12.6</u>	<u>488</u>



Xác định chiều rộng, chiều cao và diện tích thực của mỗi hình chữ nhật tỷ lệ. Làm tròn diện tích đến số nguyên gần nhất.

Câu trả lời

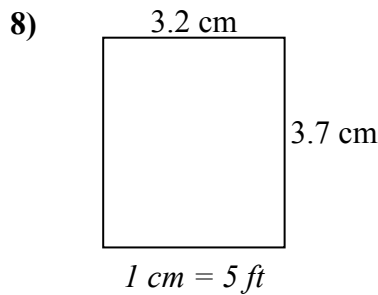
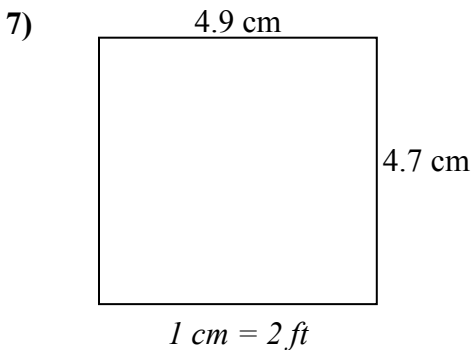
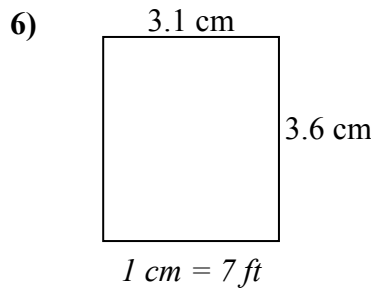
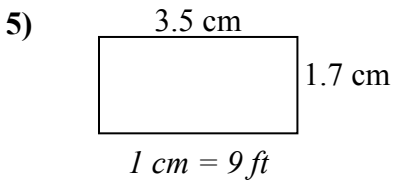
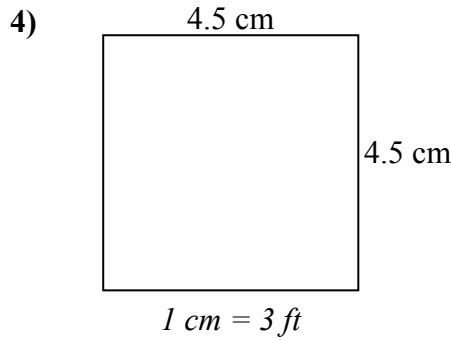
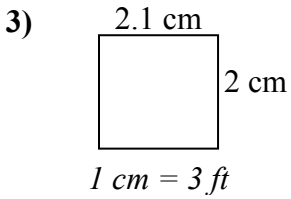
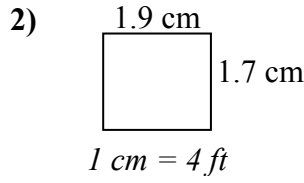
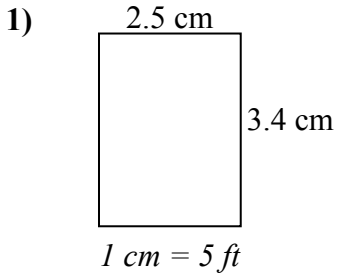

1. _____
2. _____
3. _____
4. _____
5. _____
6. _____
7. _____
8. _____



Xác định chiều rộng, chiều cao và diện tích thực của mỗi hình chữ nhật tỷ lệ. Làm tròn diện tích đến số nguyên gần nhất.

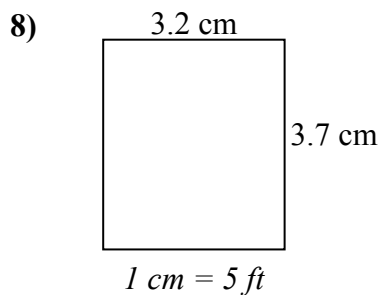
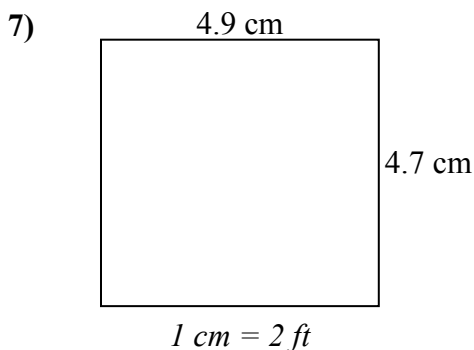
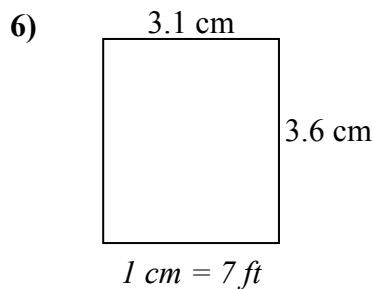
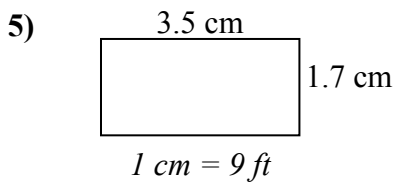
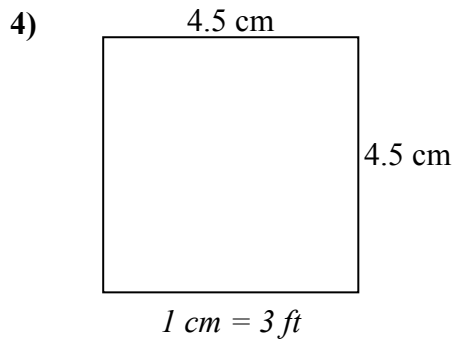
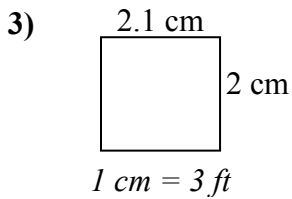
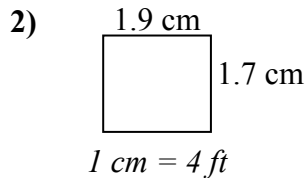
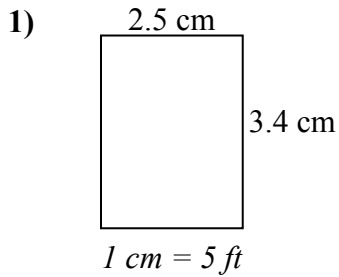

Câu trả lời

1. 12.5 17 213
2. 7.6 6.8 52
3. 6.3 6 38
4. 13.5 13.5 182
5. 31.5 15.3 482
6. 21.7 25.2 547
7. 9.8 9.4 92
8. 16 18.5 296



Xác định chiều rộng, chiều cao và diện tích thực của mỗi hình chữ nhật tỷ lệ. Làm tròn diện tích đến số nguyên gần nhất.

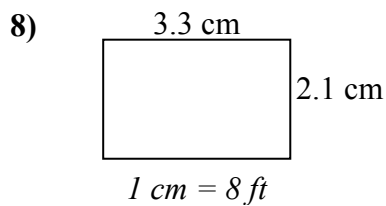
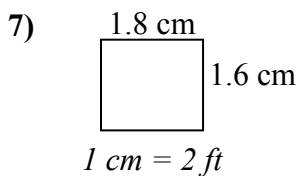
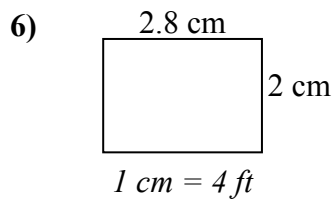
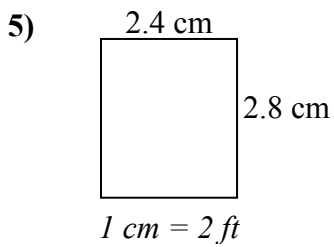
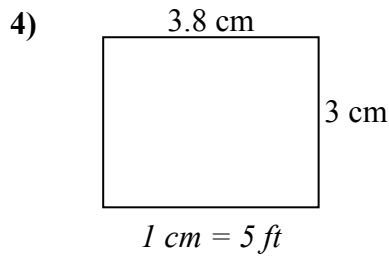
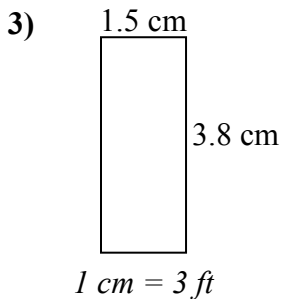
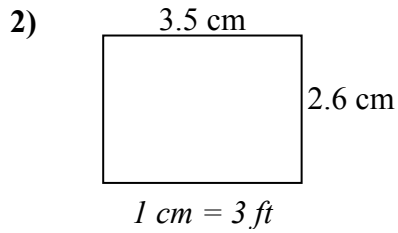
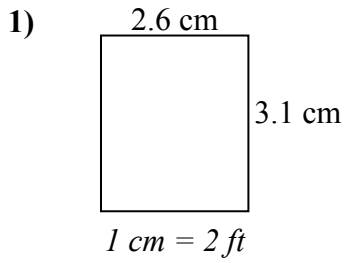

Câu trả lời

1. _____
2. _____
3. _____
4. _____
5. _____
6. _____
7. _____
8. _____



Xác định chiều rộng, chiều cao và diện tích thực của mỗi hình chữ nhật tỷ lệ. Làm tròn diện tích đến số nguyên gần nhất.

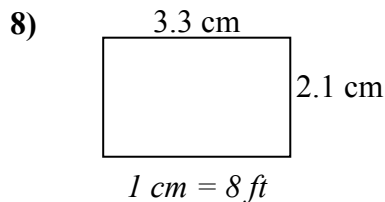
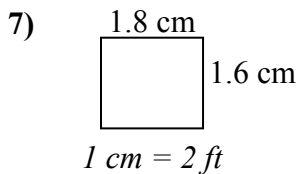
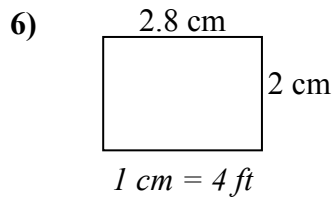
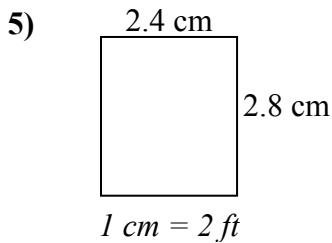
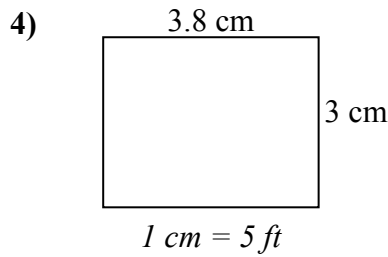
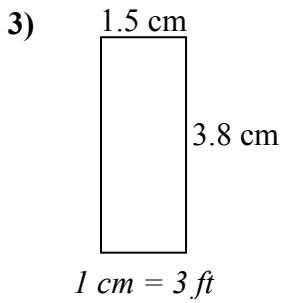
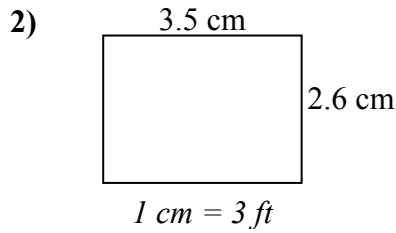
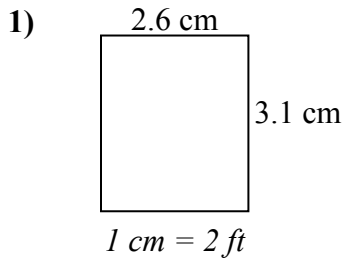

Câu trả lời

1.	<u>5.2</u>	<u>6.2</u>	<u>32</u>
2.	<u>10.5</u>	<u>7.8</u>	<u>82</u>
3.	<u>4.5</u>	<u>11.4</u>	<u>51</u>
4.	<u>19</u>	<u>15</u>	<u>285</u>
5.	<u>4.8</u>	<u>5.6</u>	<u>27</u>
6.	<u>11.2</u>	<u>8</u>	<u>90</u>
7.	<u>3.6</u>	<u>3.2</u>	<u>12</u>
8.	<u>26.4</u>	<u>16.8</u>	<u>444</u>



Xác định chiều rộng, chiều cao và diện tích thực của mỗi hình chữ nhật tỷ lệ. Làm tròn diện tích đến số nguyên gần nhất.

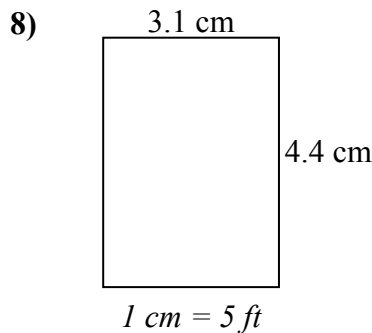
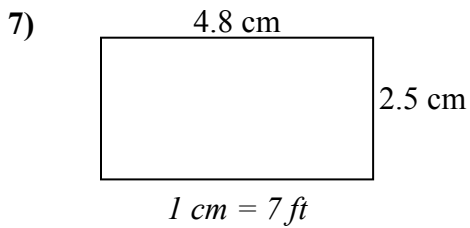
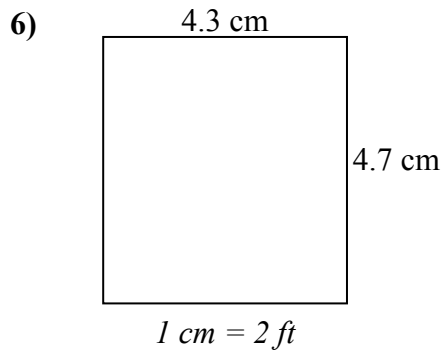
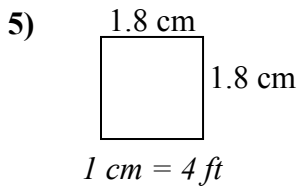
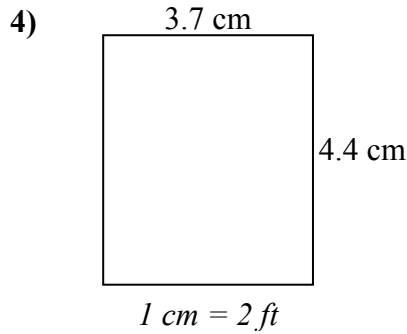
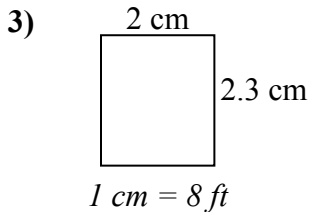
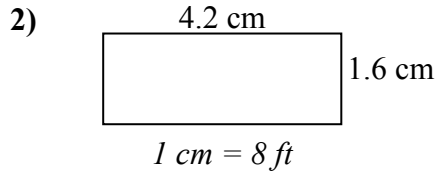
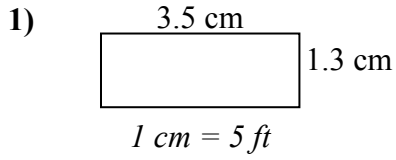

Câu trả lời

1. _____
2. _____
3. _____
4. _____
5. _____
6. _____
7. _____
8. _____



Xác định chiều rộng, chiều cao và diện tích thực của mỗi hình chữ nhật tỷ lệ. Làm tròn diện tích đến số nguyên gần nhất.

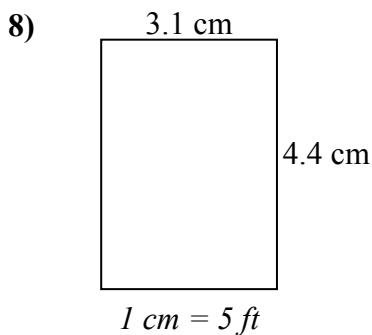
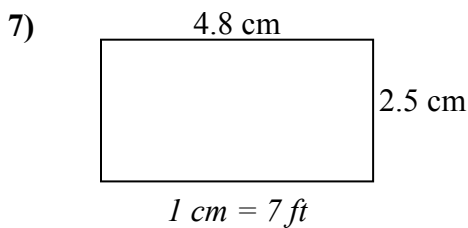
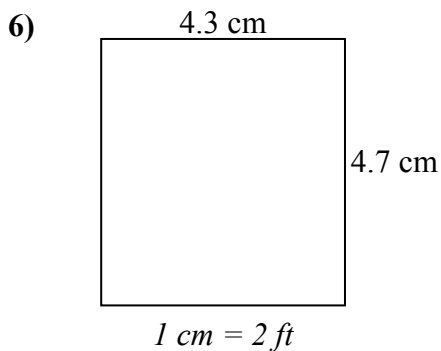
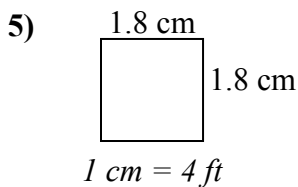
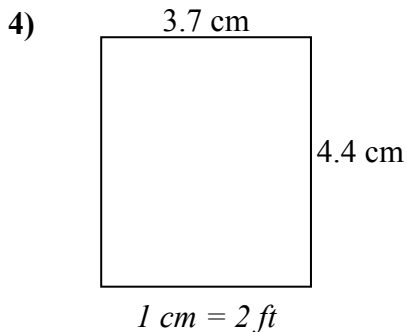
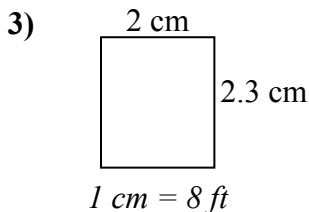
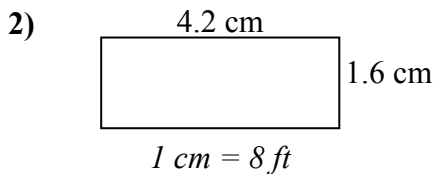
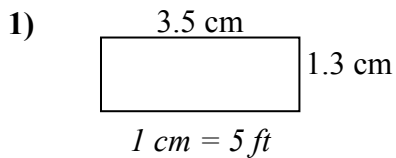

Câu trả lời

1. 17.5 6.5 114
2. 33.6 12.8 430
3. 16 18.4 294
4. 7.4 8.8 65
5. 7.2 7.2 52
6. 8.6 9.4 81
7. 33.6 17.5 588
8. 15.5 22 341